

Happy Japan

New!

HCU Series

Heavy-Duty Industrial High-Speed Embroidery Machine

1,500 RPM Maximum Speed

W600xH400mm Large Embroidery Field

W44xH45mm Compact Cylinder Bed



Standard Type
HCU-1501-40, HCU-X1501-40

Center Cross Laser Marker Type
HCU-1401-40, HCU-X1401-40

New Features

» Automatic Material Thickness Detection System



An Automatic Material Thickness Detection System is new standard function of HCU. This new function can suppress foot thumps much less than ever because HCU automatically senses a thickness of a material cloth and can adjust by itself.

» Digital Controlling System



HCU's digital controlling system uses a pressure foot enabling a height adjustment by the touch control panel. HCU's individual driving system for foot movements makes it possible to keep the foot staying at the best point to hold a material as much as it ideally is, which resulting in better finishing quality.

FACTORY OPTIONS



Center Cross Marker



Side Mounted Laser Pointer



10" LCD Panel

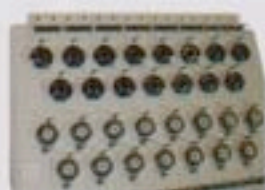

Digital Tension Control



Upper Thread Holder



Built-in Bobbin Winder

OPTION ACCESSORIES



Front table



Border Table



Various Frames



Border Frame



Safety Sensor



Assembly Type Machine Stand

Specifications

MODEL	Head	Needles	Embroidery Area (D×W)			Maximum Speed (r.p.m.)	Stitch Length	Memory
			Maximum	Wide Cap Frame	Low-profile Cap Frame			
HCU-1501-40	1	15	400×600mm 15.7×23.6inch	80×360mm 3.2×14.2inch	70×180mm 2.8×7.1inch	1,500	0.1-12.7mm	40,000,000 stitches 999 patterns
HCU-X1501-40			400×1200mm 15.7×47.2inch					

MODEL	Power Supply	Power Consumption	Frequency	Weight	Dimensions						
					L	W	H	A	B	C	
HCU-1501-40	Single Phase 110-115V 200-230V	200W	50/60Hz	99kg 218lbs	874	781	1,023	822	726	899	(mm)
					34	31	40	32	29	35	(inch)
HCU-X1501-40	Single Phase 110-115V 200-230V	200W	50/60Hz	102kg 225lbs	1,422	781	1,023	617	726	899	(mm)
					56	31	40	24	29	35	(inch)

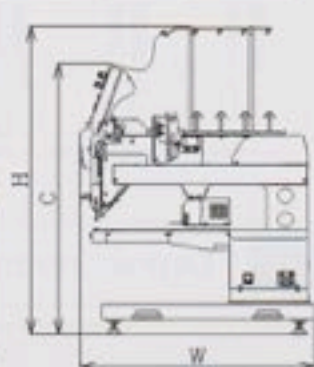
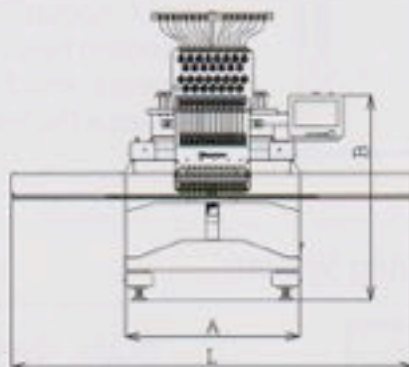
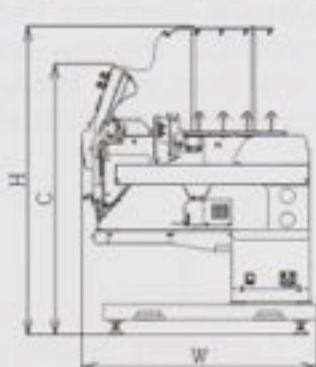
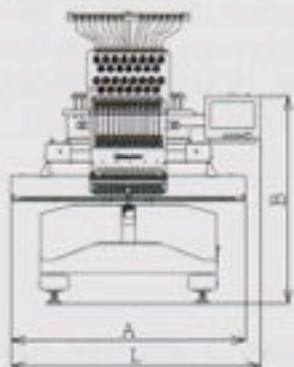

Manufactured by :

HappyJapan

HappyJapan Inc.

TOKYO OFFICE 2-9-5, Taito, Taito-ku, Tokyo, Japan
phone: +81-3-3834-0718 fax: +81-3-3835-8917
E-mail: emb-info@happyjpn.com
http://www.happyjpn.com

Distributed by :